

BlueRidge
Company™
RADIANT HEAT SYSTEMS

Wood Fired Dominator

Install Guide

Contents

| | |
|--|----|
| 1. Tools Required | 3 |
| 2. Layout and PEX Installation..... | 3 |
| 3. Pump Panel Installation | 4 |
| 4. Connect Manifold to Pump Panel..... | 5 |
| 5. Temperature/Pressure Gauge | 5 |
| 6. Boiler Connection | 6 |
| 7. Combination boilers and Indirect Water Heaters..... | 7 |
| 8. Hydronic Fill and Purge System | 8 |
| 9. Filling..... | 8 |
| 10. Air Purging Procedure | 8 |
| 11. Zone Purging..... | 10 |
| 12. Valve Adjustment | 10 |
| 13. Wiring..... | 10 |
| 14. Boiler Commissioning | 10 |
| 15. NTI Boiler Parameters | 10 |
| 16. Slab Sensor Minimum Temperature | 11 |
| 17. Set Thermostats Target Air Temperature | 11 |

1. Tools Required

- Adjustable Crescent Wrench
- Phillips Head Screwdriver
- Channel Locks
- 5mm Allen Key (included)
- 6mm Allen Key (included)
- Teflon Tape
- Pipe Dope (thread sealant)
- PEX Cutter
- Drill and Fasteners (e.g., screws)
- 18-Gauge 5-Conductor Solid Wire
- 14-Gauge 2-Conductor Solid Wire

Mr. Post Frame video series

for a full installation example of our in-floor heating system:

[Part 1](#), [Part 2](#), [Part 3](#): Coming Soon!

2. Layout and PEX Installation

Begin by reviewing your loop layout and installing the PEX tubing. Start from the furthest circuit away from the mechanical location and work your way to the closest circuit.

- A link of how to install your pex in a slab on grade system: [PEX In Concrete Slab Install Guide](#)
- A link of how to install your pex in a staple up system: [PEX Staple Up Install Guide](#)
- A link of how to install your pex in a floor panel system: [RHT Floor Panel System Install Guide](#)
- A link of how to install your pex in a staple down with topping pour: [PEX Staple Down With Topping Pour](#)

3. Pump Panel Installation

Hang your prefabricated pump panel on the wall using the predrilled holes in the panel. It is best to have at least two people for this part of the installation. We recommend adding additional fasteners if your panel width is longer than three feet. Additional framing materials should be added to provide support as needed.



Example of mechanical room layout with 3 pump RHT Dominator Pump Distribution Panel, NTI FTVN II boiler, and three RHT 4 port manifolds

Mechanical Room Layout Example

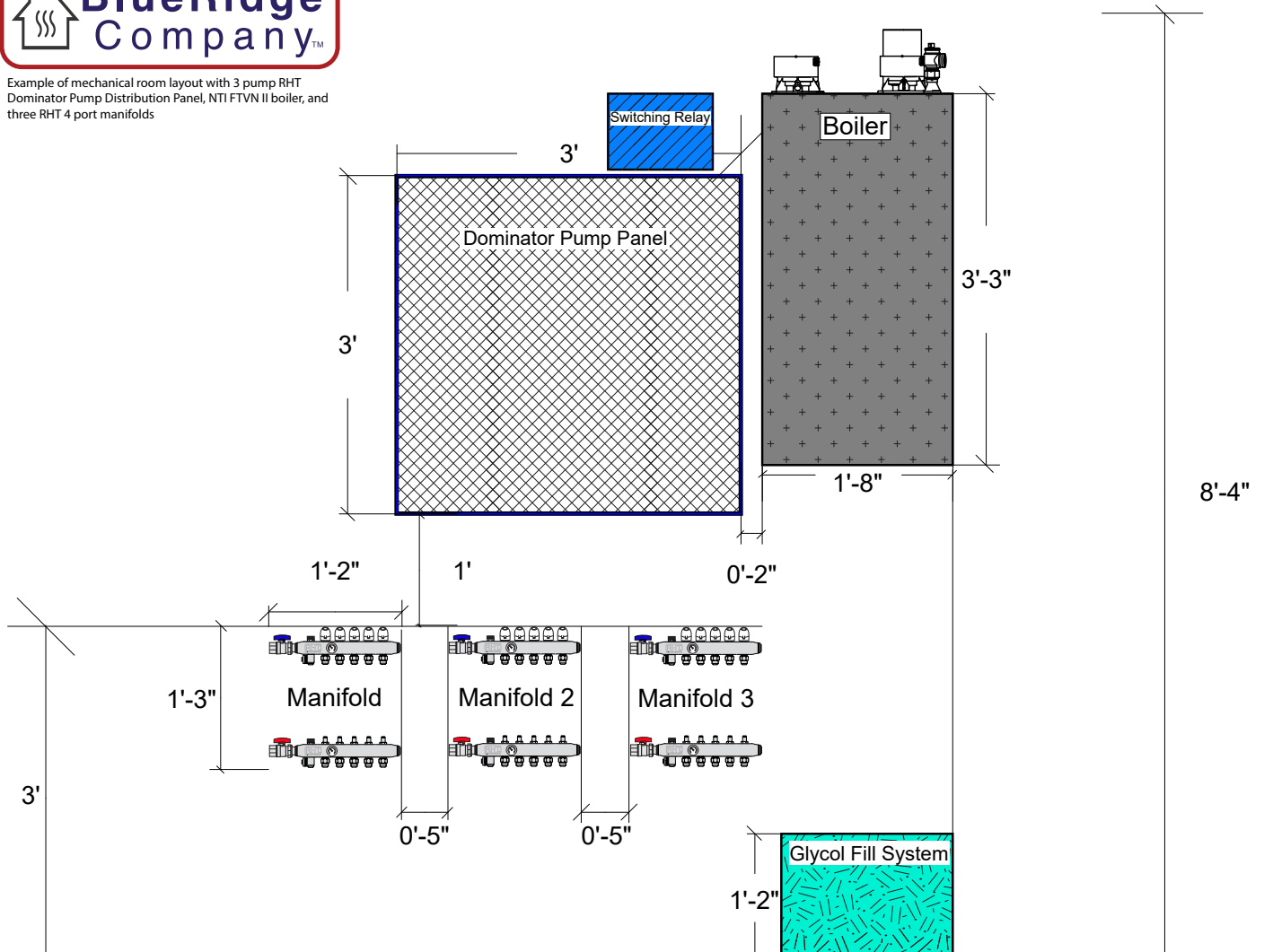

4. Connect Manifold to Pump Panel

Connect your manifold to the pump distribution panel using copper or PEX piping. The threaded fittings below will attach to the supply/return ball valves on your manifold, while the straight couplers will connect to the supply/return lines on the pump distribution panel.



5. Temperature/Pressure Gauge

Use the temperature/pressure gauge adapter fittings on the supply side of your boiler as shown in the next image. Note: Any thread-on-thread fittings that do not have a gasket need to have pipe dope and Teflon tape applied to the threads.



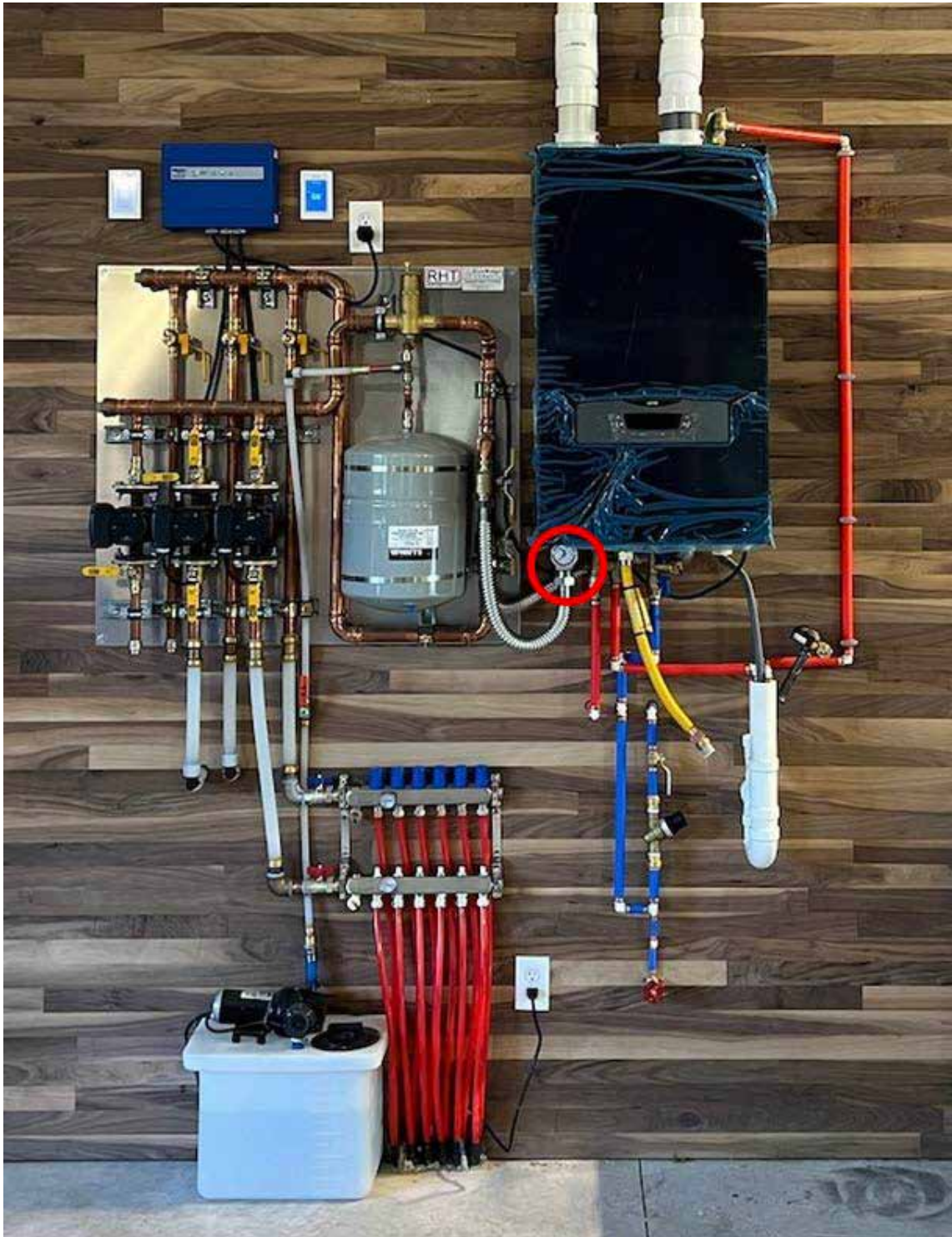

6. Boiler Connection

Connect the supply and return lines from your boiler to the prefabricated pump panel using the provided Stainless Steel Flex Boiler Connector.

7. Combination boilers and Indirect Water Heaters

Combination Boilers Only:

If you're integrating domestic hot water into your in-floor heating system using a combination boiler, we've included a tankless water heater valve set with your system. These fittings will connect to points B and D, as illustrated in the diagram for combination models below.

Indirect Water heaters Only:

If you're connecting domestic hot water to your in-floor heating system via an indirect water heater, connection F serves as the supply to your indirect water heater. You'll tee back into the central heat return connection labeled E, as depicted in the diagram for boiler models below, using the brass fittings included with your system.

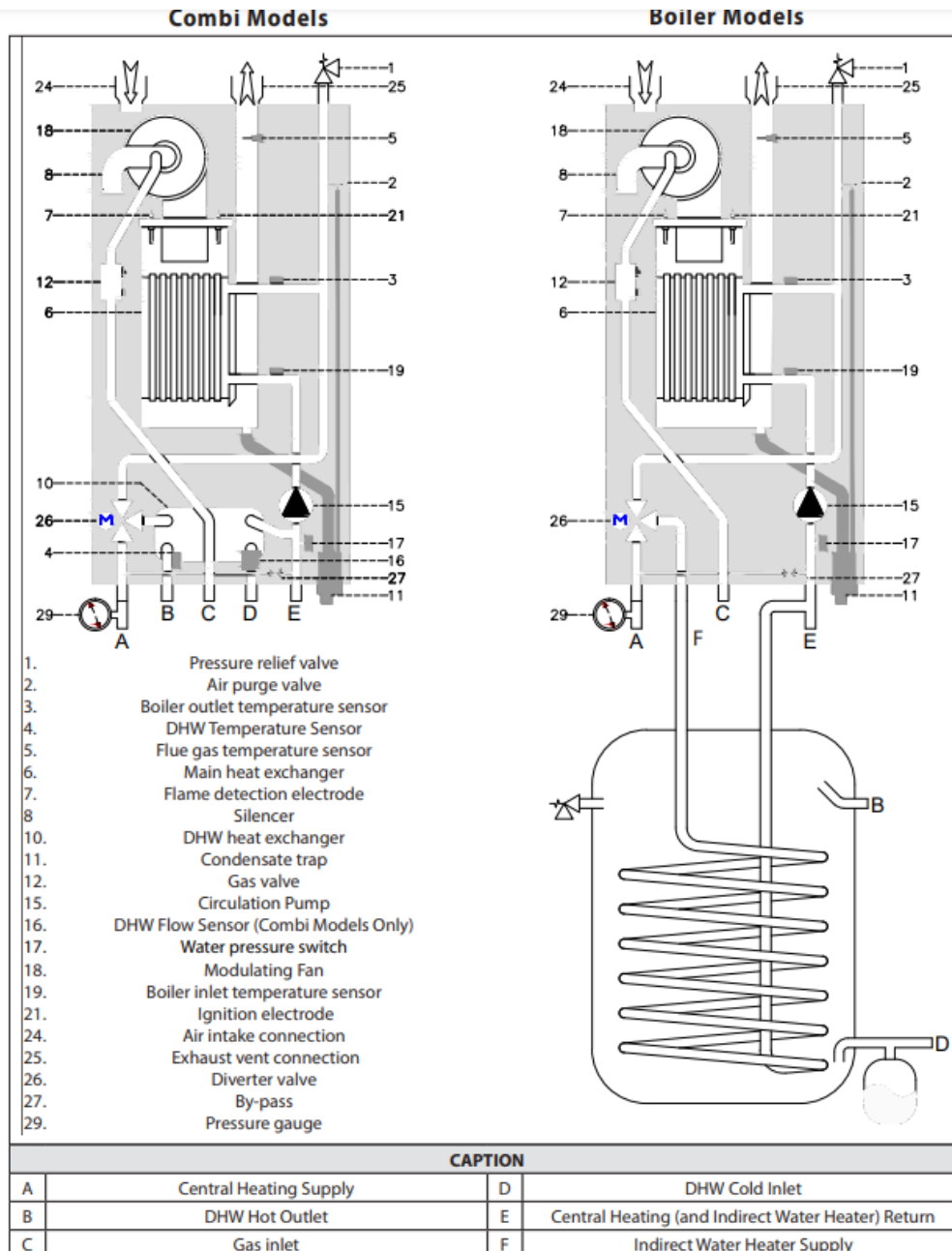

Figure 10 - Water Circuit Diagrams

8. Hydronic Fill and Purge System

Connect your fill system to the water makeup of the prefabricated pump panel using the provided fittings.



This is how you will receive your connection kit.

The 3/4" FNPT will screw onto the pump. On the pipe thread connection use a layer of thread sealer then a wrap of teflon tape, followed by another layer of thread sealer. You can Attach PEX or copper to the push fit side of the fitting.

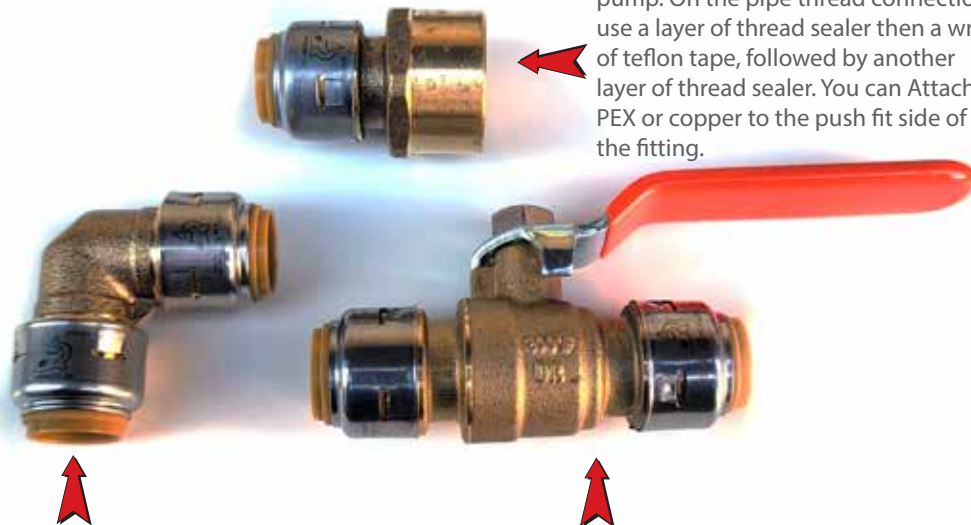

This 1/2" to 1/2" push fit elbow will allow you to make a 90° turn into the 1/2" ball valve.

This 1/2" to 1/2" push fit ball valve will attach to your water make up on your pump distribution panel.

9. Filling

Fill the reservoir with plain water or a glycol mix as appropriate. We recommend sourcing 95% Propylene glycol and for residential systems, a recommended mixture is 20-25% Propylene glycol and 75%-80% water.

10. Air Purging Procedure

Connect a hose from the return ball valve drain of a specific zone to your fill tank. Orient the valves for air purging as depicted in the illustration below and plug in the fill pump. Make sure that the reservoir remains adequately filled throughout the process. Refer back to page one of this document for guidance: [Pump Panel Diagram](#)

Dominator Pump Distribution Panel With a Set of Closely Spaced Tees for Secondary Heat Source

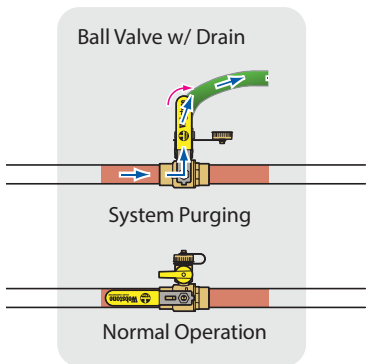
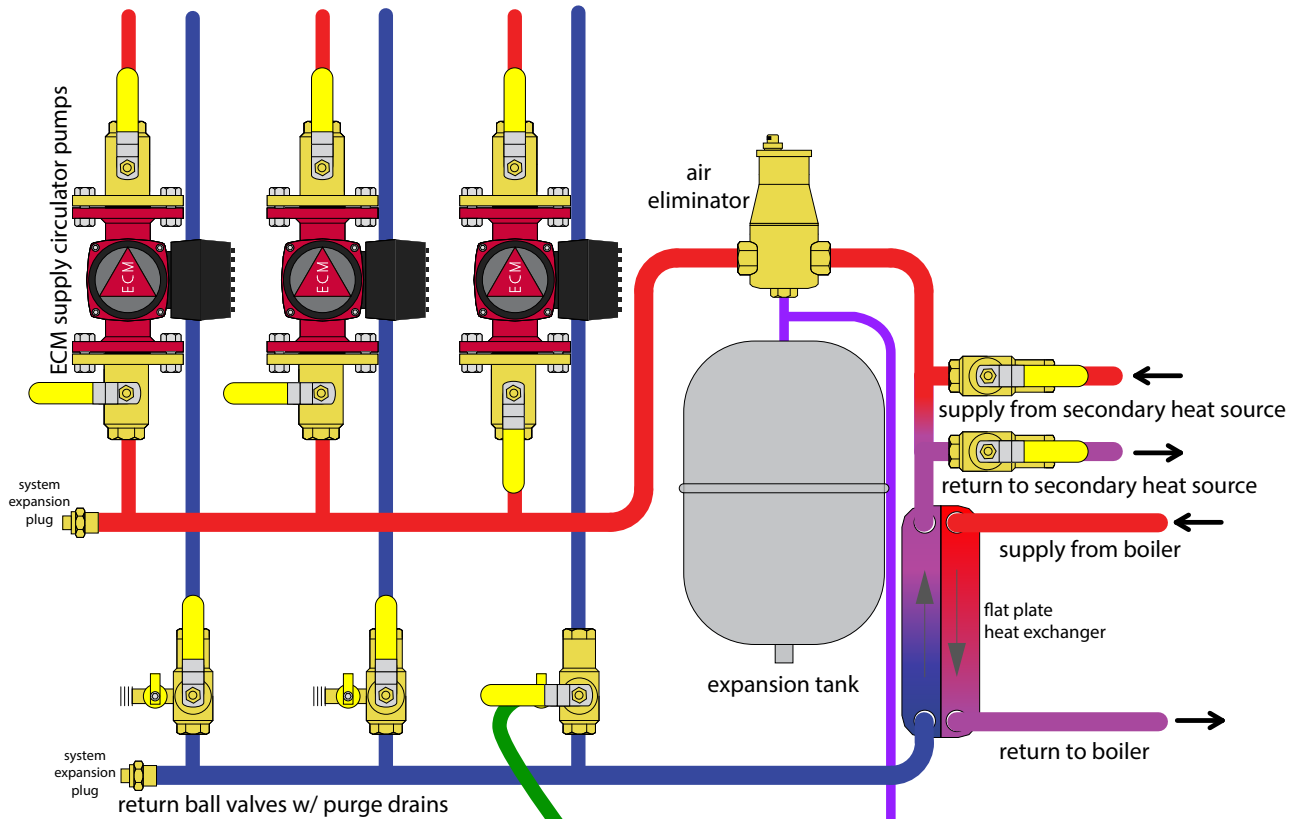

Run a hose from the ball valve drain to the RHT Hydronic Fill & Purge Unit's 4" fill port. Watch for air bubbles in the reservoir. When no more bubbles are observed, wait an additional five minutes to be certain no air is coming down the line. Once there is no more air in a given zone, close the pump flange and corresponding return ball valve, move the hose to the drain of the next zone, and repeat the process for each additional zone. An operating pressure no less than 15psi is recommended.

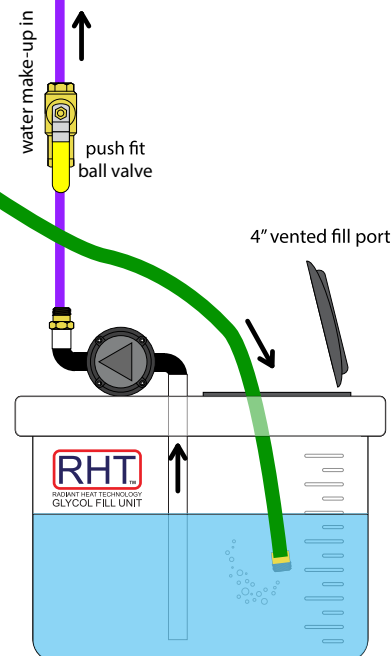

11. Zone Purging

When no more air bubbles are observed, wait an additional five minutes to be certain no air is coming down the line. Once there is no more air in a zone, close the corresponding return ball valve and move onto purging the next zone until all zones are purged. The fill pump will turn off automatically when you close the hose valve. It's crucial to keep the fill pump plugged in and connected, as it is responsible for maintaining static pressure within your system.

12. Valve Adjustment

Set all valves to their operating positions as shown on page two of the Column Pump Distribution Panel diagram.

13. Wiring

Wire the system following the recommended wiring diagram. It's advisable to have a licensed electrician handle all high voltage wiring. The recommended wiring diagram can be found here on page two: [Pump Panel Diagram](#)

14. Boiler Commissioning

Finally, refer to the boiler installation manual for guidance on commissioning the boiler:

NTI: [NTI Installation and Start-up Guide](#)

HTP: [HTP Installation and Start-up Manual](#)

15. NTI Boiler Parameters

- From the Main Menu, turn the dial to highlight "Setup Wizard" and press ENTER.
- If prompted, insert the access code; turn the dial to adjust the value to 234 and press ENTER.
- Follow the steps on page 58 of the NTI installation manual Refer to the instructions on page 58 of the NTI installation manual.
- Here is a step-by-step video tutorial: <https://www.youtube.com/watch?v=KA32hxMRzv8>

16. Slab Sensor Minimum Temperature

If you installed a slab sensor remember to set the floor minimum temperature. Available when an auxiliary floor sensor is connected, and the built-in room sensor is on.

- Tekmar 519 Thermostat:

| Setting | Display |
|--|---|
| User settings. Press the Δ and ∇ buttons together for 3 seconds to enter and advance to the next setting. | |
| MODE Select heat or off. Range: HEAT, OFF | MODE HEAT Default: HEAT |
| UNITS Select the temperature units. Range: °F or °C | UNITS F Default: °F |
| LIGHT Select when the display back light should operate. Auto operates the backlight for 30 seconds after a keystroke. Range: OFF, AUTO, ON | LIGHT AUTO Default: AUTO |
| SET FLOOR Set the floor minimum temperature. Available when an auxiliary floor sensor is connected and the built-in room sensor is on. Range: OFF, 40 to 122°F (4.5 to 50.0°C) | SET FLOOR 72 Default: 72°F (22.0°C) |
| TYPE Device Type number. Hold the Δ button to view the software version. | TYPE 519 |
| ESCAPE Release the Δ and ∇ buttons to return to the home screen. | ESCAPE |

- Tekmar 561 Thermostat:

| Setup - Temp | | |
|---|---------------------------------------|---------|
| Setting | Range | Default |
| <i>Screen Page 1</i> | | |
| FLOOR MIN - WAKE Select the floor temperature while in the wake schedule. Applies when there is both a floor and an air sensor. | Off, 40 to 95°F Off, 4.5 to 35.0°C | Off |
| FLOOR MIN - LEAVE Select the floor temperature while in the leave schedule. Applies when there is both a floor and an air sensor. | Off, 40 to 95°F Off, 4.5 to 35.0°C | Off |
| FLOOR MIN - RETURN Select the floor temperature while in the return schedule. Applies when there is both a floor and an air sensor. | Off, 40 to 95°F Off, 4.5 to 35.0°C | Off |
| FLOOR MIN - SLEEP Select the floor temperature while in the sleep schedule. Applies when there is both a floor and an air sensor. | Off, 40 to 95°F Off, 4.5 to 35.0°C | Off |
| FLOOR MIN - AWAY Select the floor temperature while in away. Applies when there is both a floor and an air sensor. | Off, 40 to 95°F Off, 4.5 to 35.0°C | Off |

17. Set Thermostats Target Air Temperature

On the home screen of your thermostat, set the desired temperature for that zone.

If you have any questions, please do not hesitate to reach out at 866-361-4782 and dial 3 for technical support.